

P103050 – P-1000 INSTALLATION & INSTRUCTION MANUAL



REVISION PAGE

ORIGINAL NUMBER	NEW NUMBER	DATE	INITIAL	DESCRIPTION
P103050 Rev. A	P103050 Rev. B	04/24/91	tjkl	Added Graphics
P103050 Rev. B	P103050 Rev. C	09/16/91	tjkl	Updated for STC Release
P103050 Rev. C	P103050 Rev. D	03/12/92	tjkl	Added installation checklist, landscape format used, new cover graphic, revised features section and the warranty changed.
P103050 Rev. D	P103050 Rev. E	05/01/03	GAZ	Address change with minor text changes.

TABLE OF CONTENTS

Introduction	4	Maintenance	19
P-1000 Features	5	Trouble-Shooting	19
Technical Specifications	6	Common Failures of Ignition System	21
RTCA Environmental Qualification Statement	7	Warranty	22
Certification	8		
Theory of Operation	9		
Display Features	10	Figure 1, P-1000 Features	5
Liquid Crystal Display	10	Figure 2, Typical Signal on Magneto P-Leads	9
Status Indicators	10	Figure 3, Typical Magneto Electrical Installation	9
RPM ACR Indicators	11	Figure 4, Magneto Ignition System Electrical Diagram	10
MAG-DROP Display Mode	11	Figure 5, Rear Panel Connections	16
Operation	11	Figure 6, Typical Single Engine Magneto Locations	16
LED Dimming	11	Figure 7, Optimum LCD Viewing Angles for Installation	18
Tachometer Control	12	Figure 8, Typical Wiring Diagram	18
Engine Clock	12		
Reset	12		
Installation	13		
Static Precautions	13		
Unpacking and Inspecting the Equipment	13		
The Installation/Check-Out Sequence	13		
Connections	16		
Removal of Mechanical Tachometer	17		
Instruments Mounting	17		
Circuit Breaker	18		

INTRODUCTION

Thank You for purchasing the Horizon Instruments' P-1000 Digital Aircraft Tachometer. Many features have been incorporated into the design of the P-1000 insuring simple operation and long life. The P-1000 represents the state-of-the-art in applying computer technology to aircraft engine control and will prove to be invaluable in the reliable and safe operation of your aircraft.

The P-1000 functions as two fully independent digital tachometers that monitor the signals received from the primary circuits of the aircraft's magnetos. The internal right and left tachometers independently determine engine RPM, which is then average and displayed for the pilot. The superior reliability of the tachometer design is due to the use of two separate magneto signals to generate two identical RPM readings. If either magneto fails, the tachometer will continue to display RPM from the remaining functional magneto. No external probes or sensors are required to be installed in the harsh engine environment, further reducing the possibility of failure, and simplifying installation.

Easy installation is facilitated by wiring the P-1000 to the P-Leads of the ignition switch. In most cases, no additional wires need be run into the engine compartment.

To be sure of obtaining the best possible performance from the P-1000 please be sure to read this Instruction Manual carefully and become thoroughly familiar with the operation of the P-1000 before starting its use.

KEEP THIS MANUAL HANDY FOR FUTURE REFERENCE.

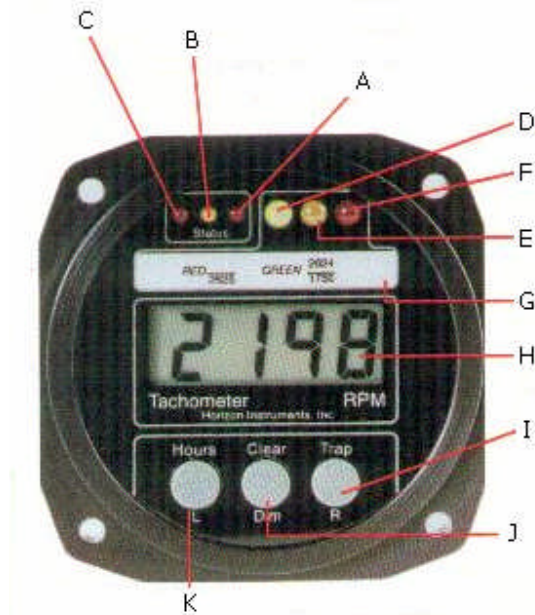

Figure 1, P-1000 Features

- A Right Magneto Signal Status Indicator. Turns on with the Loss of Signal from the Right Magneto. Flashes when the Right Internal Tachometer is Disabled.
 - B Magneto Error Indicator. Illuminates to indicate that there is a difference in RPM reported from each Magneto.
 - C Left Magneto Signal Status Indicator. Turns on with the Loss of Signal from the Left Magneto. Flashes when the Left Internal Tachometer is Disabled.
 - D Green, "Normal Operating" Range Indicator. Illuminates when the Engine RPM is within its specified normal operating ranges.
 - E Yellow, "Warning, Cautionary or Transient" Range Indicator. Illuminates when Engine RPM is within its specified Cautionary or Transient Operating Ranges.
 - F Red, "Restricted Operating" Range Indicator. Illuminates when the Engine RPM is within its specified Restricted Operating Ranges.
- UP TO FIVE SEPARATE RPM RANGES MAY BE FACTORY PROGRAMMED.**
- G Placard Area
 - H Full 4 Digit High Visibility Back-Lit ½" Liquid Crystal Display
 - I RPM Overspeed Trap Recall Button/Right Tachometer Enable/Disable.
 - J RPM Overspeed Trap Clear Button/Indicator Dimmer.
 - K Engine Hours Recall Button/Left Internal Tachometer Disable. **ENGINE HOUR METER CAN BE FACTORY PRE-SET TO START WHERE THE REPLACED TACHOMETER STOPPED.**

Two fully independent tachometers in one panel-mounted instrument increase tachometer reliability in case of either magneto's failure. Tachometer monitors both magneto P-Leads for redundant RPM sensing and magneto performance comparisons. Non-Volatile memory won't forget engine hours or factory pre-sets, no battery required. Eliminates tachometer cables, oil seal problems and accuracy problems associated with mechanical tachometers. Light weight, sturdy construction, easy to install.

Long term stability due to the use of all digital techniques, accuracy better than 1 RPM. Vibration, temperature, and electromagnetic interference, do not affect accuracy. Detection of RPM differences between magnetos and possible magneto failure. Automatic display of "MAG-DROP" RPM when a magneto pre-flight is performed. Visual indication of possible "HOT-MAG" or shorted magneto conditions. Operates with any number of engine cylinders.

TECHNICAL SPECIFICATIONS

Input Frequency Range: Up to 400 magneto firings per second, per tachometer
12,000 RPM on a 4 cylinder engine, 5,333 RPM on a 9 cylinder engine

Input Signal Voltage: 100 to 1000 Volts AC

Accuracy: +/- 1/2 RPM, each tachometer

Cylinder Configurations: 4,6,7,8,9,11,12,14

Input Impedance: Greater than 500,000 ohms, each tachometer input

Power Requirements: 7.5 – 31 Volts, DC, 200 ma. max

Environment:

Weight: 1.5 lbs.

Dimensions: 3 inch MSM33638 Case, 2 3/4" deep

Switch Operational Life: Greater than 250,000 cycles

Cabling: Shielded P-Lead wire to ignition switch. MS3106A-14S-6S Connector with AN-3057-6 Strain Relief

MTBF 20,000 Hours

Warranty: Limited Two Years, Parts & Labor.

Engine Hours Clock: Accurate to less than 1 hour error in 2000 hours. Records real time when engine RPM is greater than 800.

Software Certifications: Software certified to RTCA DO-178A, level 2.

The P-1000 Electronic Digital Engine Tachometer is designed to meet the following environmental test categories of RTCA DO-160-C.

CONDITIONS	PARAGRAPH NUMBER	DESCRIPTION OF CONDUCTED TESTS	CONDITIONS	PARAGRAPH NUMBER	DESCRIPTION OF CONDUCTED TESTS
Temperature & Altitude	4	Tested to categories A1 & B1.	Fluids Susceptibility	11	Equipment Identified as "X". No Test Required.
	4.5.1	Ground Survival (-55 C) & Low Operating Temperature Tests (-20 C)	Sand & Dust	12	Equipment Identified as "X". No Test required.
	4.5.2	Ground Survival (+85 C) & High Short Time Operating Temperature Test (+70 C).	Fungus	13	Equipment Identified as "X". No Test Required.
	4.5.3	High Operating Temperature Test (+55 C)	Salt Spray	14	Equipment Identified as "X". No Test Required.
	4.6.1	Altitude (+25,000Ft)	Magnetic Effect	15	Tested Per Category "Z". No compass deflection in each axis.
	4.6.2	Decompression Tests (8,000Ft to 25,000Ft)	Power Input	16	Tested Per Category "B". EUT operated normally during all test conditions.
	4.6.3	Overpressure Tests (-15,000Ft)	Voltage & Spike, Conducted	17	Tested Per Category "B". EUT displayed no malfunctions or degradations during testing.
Temperature Variation	5	Tested Per Category "B". Equipment will withstand better than 5 C/min temperature change.	Audio Frequency Conducted Susceptibility	18	Tested Per Category "B". EUT displayed no malfunctions or degradations during testing.
Humidity	6	Tested per Category "A". 95% Humidity	Induced Signal Susceptibility	19	Tested Per Category "B". The EUT showed no signs of susceptibility during this test.
Shock	7.2	Operational Shock Test, 6gs in 11ms. ½ sine, 3 shocks per axis, each direction.	Radio Frequency Susceptibility	20	Tested Per Category "U". The EUT showed no signs of susceptibility during this test.
	7.3	Crash Safety Test, impulse and Sustained Shock. 15gs in 11ms. ½ sine performed on each axis.	Radio Frequency Emissions	21	Tested Per Category "B". The EUT's emissions were within the test requirements.
Vibration	8	Tested per "Standard Vibration" requirements. Resonance scans detect no resonance in each axis.	Lightning Induced Transient Susceptibility	22	Tested Per Category "K". These tests had no effect upon the EUT.
Explosion	9	Test Not Applicable.	Lightning Direct Effects	23	Tested Per Category "X".
Waterproofness	10	Equipment Identified as "X". No Test Required.	Icing	24	Tested Per Category "X".

CERTIFICATION

The P-1000 is installable into an aircraft under one of the following conditions:

1. With an STC issued for your model aircraft allowing the P-1000 to replace the existing mechanical tachometer.
2. With a one-time-only STC issued for installation of the P-1000 on your aircraft, this is typically referred to as a "Field Approval".

A P-1000 purchased with an STC for replacement of the existing mechanical tachometer will have attached to this documentation package:

- Supplemental Instructions and Drawings pertaining to the specific installation of the P-1000 in the indicated aircraft.
- Flight Manual Supplement
- A copy of the applicable STC

The Supplemental STC information supplied with a P-1000 is dependent upon the information supplied to Horizon Instruments, Inc. at the time the P-1000 is ordered. If this information is erroneous, applicable to a different type of aircraft, or missing, do not proceed with installation. Contact the Horizon Instruments, Inc. Technical support staff for further instructions.

NOTE:

The STC Approval accompanying a P-1000 tachometer is considered proprietary information by horizon Instruments, Inc. and is not applicable to any other manufacturer's equipments.

THEORY OF OPERATION

The P-1000 operates by timing the alternating electrical signals generated by an operating magneto, see Figure 2, and made available on the magneto's "P" or grounding leads. Because reciprocating engine aircraft have two magnetos on each engine (See Figure 3), the P-1000 provides two terminals for connection to these "P" leads of the right and left magnetos of the engine. These "P" lead signals are generally only a few hundred volts as compared to the secondary output of the magneto, which may generate tens of thousands of volts used to create sparks at the spark plugs.

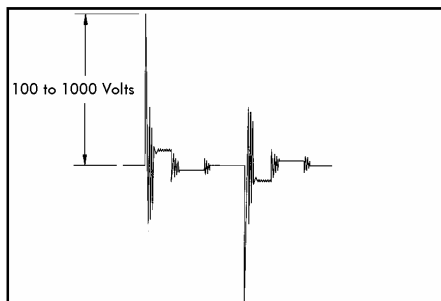

Figure 3, Typical Magneto Electrical Installation, With P-1000

RPM is derived from the repetition rate of the signals received from the magnetos, and not the amplitude or shape of these signals. This rate corresponds to the firing of the engine's spark plugs, and thus, the turning of the engine.

The Microprocessor functions as two internal tachometers. It has the ability to compare and store the RPM of each tachometer. A difference of RPM reported from the two magnetos of the same engine indicates that one of the magnetos may be failing (i.e. Mis-firing, severe fouling, sticking or floating points, etc.).

The RPM displayed on the LCD is the average of the right and left tachometer's RPM. Thus, if either tachometer begins to fluctuate or act erratically, due to failure in its ignition system, the error will show in the display. Mechanisms are provided to mask these erroneous RPM values and allow operation from the signal of the functional magneto.

Loss of a signal from either magneto is detected by the corresponding internal tachometer and a signal status indicator is turned on to indicate the error. Short term (< 1/2 second) differences between the right and left tachometers are also indicated to the pilot with a yellow status indicator.

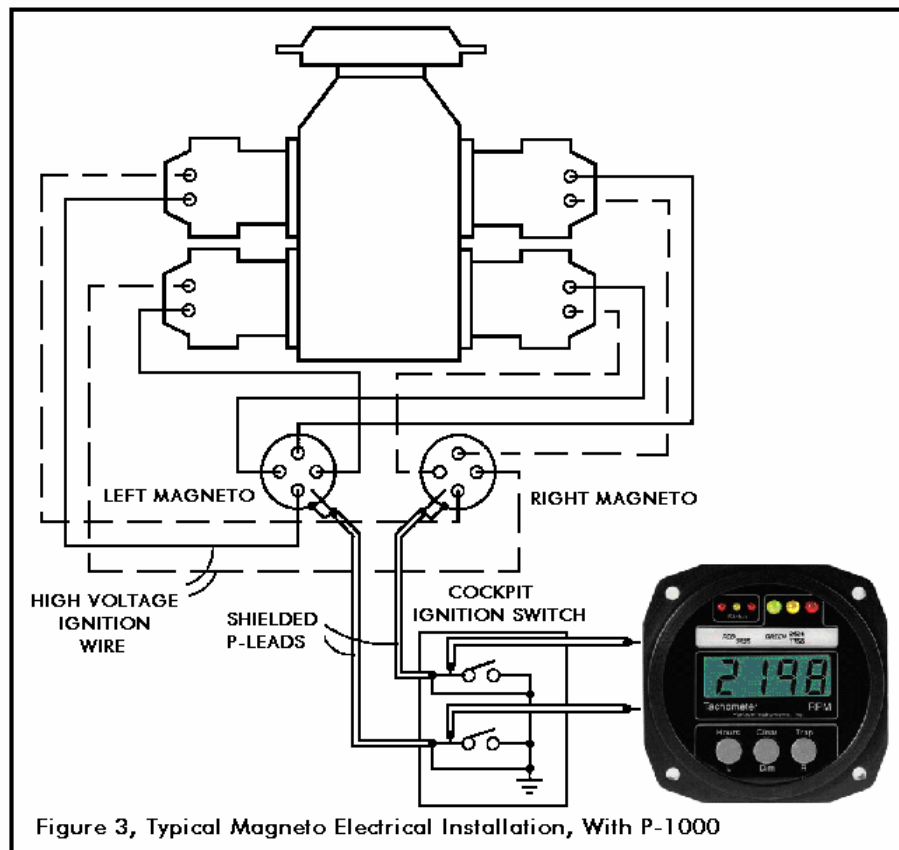

Figure 3, Typical Magneto Electrical Installation, With P-1000

Engine hours are recorded in real time beginning when the engine is assumed to be able to sustain combustion, at or above 800 RPM. A high accuracy engine clock yields true TBO times (engines are rated in real hours, not RPM-hours) and more accurate fuel consumption calculations.

Using the internal microprocessor to compare RPMs from each internal tachometer against a previously known highest RPM, and storing the new highest RPM creates the "Overspeed Trap" feature. Provisions are made to clear this trap at any time. The Overspeed Trap is saved when the P-1000 is turned off.

DISPLAY FEATURES

LIQUID CRYSTAL DISPLAY

The P-1000 provides easy to read ½ inch high characters on a liquid crystal display (LCD). A "straight line" (displayed using hyphens) is displayed on the LCD when the P-1000 is not receiving a signal from either magneto. This is generally noticeable when the P-1000 is turned on and the engine is not started.

STATUS INDICATORS

When no signal is received from either the right magneto or left magneto (See Figure 1), the P-1000 will turn on a corresponding right or left red magneto signal "Status" indicator. The status indicators are located on the upper left of the tachometer face and can indicate a hot magneto (open circuit) or grounded magneto (breached insulation or broken ignition switch) condition. The indicators turn on after ½ second passes without receiving a pulse from a magneto, and will turn off when the signal is restored.

Another status indicator is located between the red magneto signal indicators. This yellow indicator is a warning that the P-1000 has detected different RPM from the signals provided by each magneto. This is typical of a failing set of points or an intermittent wiring problem. The yellow status indicator may be accompanied by a red magneto signal status indicator, but under some conditions, may appear by itself. See the Troubleshooting section for more information. This indicator operates as a threshold set at the maximum allowable difference between the mag-drop readings of each magneto.

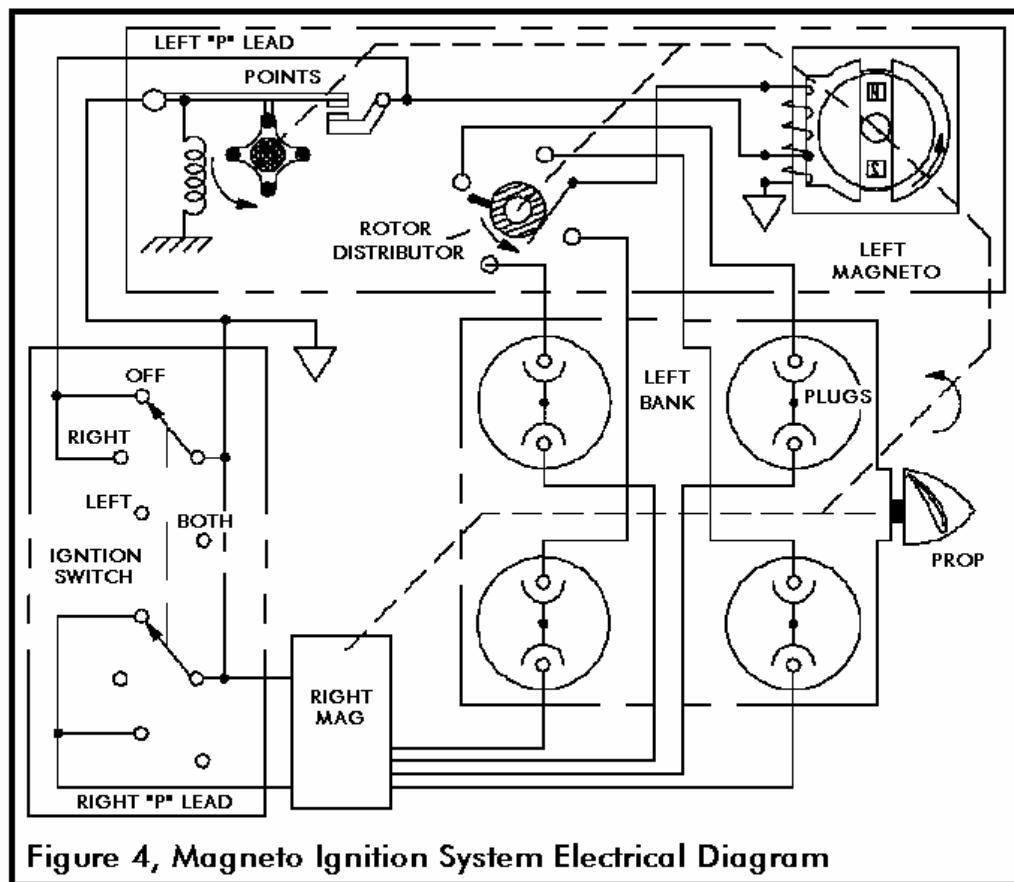

Figure 4, Magneto Ignition System Electrical Diagram

RPM ARC INDICATORS

Three large LED type indicators are provided at the upper right corner of the P-1000 face to indicate the RPM operating range of the engine (See Figure 1). A "Normal Operating " green, "Caution" yellow, and "RED-LINE" red LED are provided. The RPM settings at which these indicators activate are presettable at the factory. Five separate RPM arcs can be factory programmed into the P-1000.

MAG-DROP DISPLAY MODE

Loss of either magneto signal causes the P-1000 to turn the appropriate status indicator, remember the engine RPM at the time the signal was lost, and display the drop in engine RPM that resulted from the loss of the magneto. When this feature is used in conjunction with the ignition switch, pre-flight magneto performance tests, or "Mag-Drop", can be easily and accurately performed. During this mode of operation, the LCD should show a small RPM number, normally preceded by a minus sign ("-") indicating that the engine slowed down. A display without a minus sign indicates an engine that has increased in speed. If the loss of signal remains for more than fifteen seconds, the P-100 will revert back to displaying the engine RPM, determined from the remaining functioning magneto.

OPERATION

Three buttons on the face of the P-1000 control the information being displayed to the pilot. These buttons have two modes of operation: press-and-hold, and press-and-release. The press-and-hold operation is used to control information displayed on the liquid crystal display. Each button must be pressed and held for one second to change the display. Pressing and holding the right button causes the Overspeed trap to be displayed. This function is denoted on the P-1000 face by the word "TRAP" above the button. Pressing and holding the center button for one second will cause a zero to be displayed. This causes the Overspeed trap to be cleared, and the button is marked with the word "CLEAR". Pressing and holding the left button for one second will cause the engine hours to be displayed. While the button is being held, the integer portion of the engine hours is displayed. Upon release of the button, the fractional portion of the engine hours is displayed for five seconds, then the display reverts back to displaying RPM. This function is marked on the P-1000 by the word "HOURS" above the left button. Press-and-release operations modify the operation of the internal tachometers and control display characteristics. The press-and-release operation must occur within one second to distinguish the operation from the press-and-hold operations described above.

LED DIMMING

A press-and-release operation on the center button causes the LED indicators (except for the red LEDs) to be dimmed. Pressing the button again restores the LEDs to full intensity. This feature is handy for night flying because an LED bright enough to overcome sunlight washout may be annoyingly bright at night. This function is marked "DIM" on the P-1000 face under the center button. The red RPM range indicator is not dimmable.

TACHOMETER CONTROL

Because a bad or failing magneto may affect the RPM displayed on the liquid crystal display (see Theory section), a mechanism is provided to mask the erroneous RPM information from the display. An Erroneous or erratic RPM display may be accompanied by one or more of the status LEDs illuminating.

Press-and-release operation of the right and left buttons causes the right and/or left tachometers to be alternately masked and un-masked from the display. This is a toggle type feature: a masked tachometer will be un-masked, or allowed to affect the display, when the button is pressed, or an un-masked tachometer will be prevented from affecting the display when the button is pressed.

When the RPM displayed on the P-100 is suspected to be wrong, is jittery or erratic, does not track the engine properly, or one or more of the status indicators are turned on or are flickering, it is likely that one of the ignition systems has a problem.

The procedure to find the bad ignition system is to isolate the RPM from each internal tachometer can check the results. Mask each tachometer, one at a time, starting with the tachometer corresponding with any flickering red status LED to try to stabilize the RPM on the display. A tachometer that appears to be varying wildly or not properly tracking the engine is the culprit and should be masked from the display to allow normal operation of the P-1000 on the remaining good magneto.

A tachometer that is masked is indicated by the corresponding status LED flashing regularly at a one second rate. Care should be taken not to interpret this indication as a loss of signal condition. The yellow status indicator is inhibited when either tachometer is masked.

ENGINE CLOCK

Your tachometer may have been pre-programmed at the factory for other than zero engine hours. When ordering your P-1000, a review of your logs may have been necessary to determine the correct time for the tachometer display. Any correction or change in time must be recorded in the appropriate log book.

Recording tachometer, such as the P-1000, are considered by the FAA to record engine hours, not airframe hours. Thus, the tachometer should be ordered with zero hours if being installed with a zero time engine. Allowing the tachometer to run past engine changes in hopes to accumulate total "Time In Service" is not proper, as the engine operates long before the aircraft leaves the ground, see FAR 1.0.

Also, Horizon Instruments, Inc. provides a service to zero or correct your engine hours when engines are changed, or to adjust a tachometer display for the proper engine hours reading.

RESET

The computer within the P-1000 may be manually reset if it is suspected that it is not operating properly. To accomplish the reset, simultaneously press the center and right buttons. The P-1000 should proceed through its self-check tests and resume full operation.

INSTALLATION

At all times, installation procedures should follow good aviation installation practices as per FAA Advisory Circulars 43.13-1A Chapter 2 and 43.13-2A Chapter 11, and this manual. Because the P-1000 is installed and approved using a Supplement Type Certification procedure, supplemental instructions specific to your aircraft are included with this tachometer. These additional instructions take precedence over this manual.

STATIC PRECAUTIONS

Proper operation of the P-1000 requires that all grounding straps to the engine block and instrument panel be in place. The magneto P-Leads carry signals that are very prone to conduction into adjacent circuits/wires/metals. An adequate return path to the magneto must be maintained to prevent interference with other electronics equipment.

Normally the P-1000's ground terminal for the power buss is adequate for this purpose, however, the wires connecting the P-1000 to the magnetos are shielded, and those shields may be grounded at the magneto, or to the shields of existing P-Leads at the ignition switch. Older aircraft may not employ shielding wire.

UNPACKING & INSPECTING THE EQUIPMENT

Exercise care when unpacking the P-1000. Make a visual inspection of the tachometer for any evidence of damage incurred during shipping.

It is good practice to retain the shipping containers and packing materials if it should ever become necessary to return the P-1000 for service, maintenance, or modification.

Save all packing slips, invoices, warranties, and manuals in a secure area for future reference.

The shipping container will need to be returned to Horizon Instruments, Inc. to substantiate any claims of damage due to shipment. Prior to returning any product to Horizon instruments, Inc., please call for a return materials authorization number so that your product can be properly and expediently tracked and processed.

Verify the RPM arc information placarded on the face of the P-1000 to correspond with the red, yellow and green arcs on the existing mechanical tachometer, or to the engine/propeller manufacturer's specifications.

THE INSTALLATION/CHECK-OUT SEQUENCE

The following steps are a general outline for the installation and checkout of the P-1000 Tachometers:

- 1 Verify that all tools and materials to complete the installation are available.
- 2 Locate the tachometer on the instrument panel and verify that there is a sufficient clearance for the P-1000 and attached cable behind the panel when installed.
- 3 Locate the recommended circuit breaker installation on the electrical panel. Verify that the cable provided will reach from the P-1000 installation to the circuit breaker.
- 4 Locate the ignition switch on the electrical panel. Again verify that sufficient length of cable is available to reach from the P-1000 to the ignition switch. The P-Lead wires should be routed away from any radio or other sensitive electronic equipment, and maintains proximity to grounded panel structures. Maintain three inches clearance from any other electrical wiring.
- 5 Determine the routing of the cable from the P-1000 to the ignition switch and circuit breaker. Remember to leave adequate service loops and properly strain relieve the cable ends.
- 6 Cut the power wires to proper length, strip 3/8" from the ends and attached the ring-tongue terminals supplied.
- 7 Verify that the main power switch is turned "OFF".
- 8 Attach the black wire to a suitable ground, preferably to a metal surface or supporting structure.
- 9 Install the circuit breaker. Turn on the main power switch and verify the operation of the circuit breaker. Turn off the main power switch. Note: the circuit breaker should be installed on the main power buss, not the instrument power buss.
- 10 Attach the white wire to the circuit breaker load terminal.
- 11 Attach the circular connector to the P-1000. Be sure to screw the retaining ring all the way to the base of the mating P-1000 connector. Turn on the main power switch and verify that the P-1000 turns on. The P-1000 will flash the tachometer's configuration number, which identifies the tachometer for use with a specific aircraft/engine combination, and a software version code. The version code has a decimal point in it, the configuration code does not.
- 12 Turn off the main power switch.
- 13 Attach the left and right P-Lead wires to the ignition switch. Be sure to make the proper left and right connections to the left and right magnetos. Use the ring-tongue connectors wherever possible. DO NOT CUT OR SPLICE THESE CABLES. They contain shields to protect other instruments in the aircraft from interference from ignition noise. If the shielded wires are too short, please contact Horizon Instruments, Inc. for a longer cable. Be sure that no frayed wires are present, and that all screw connections are secure.
- 14 At this point, the P-1000 may be placed in a secure location prior to starting the engine.

- 15 Turn on the main power switch and verify the P-1000 again turns on.
- 16 Press and hold the left button and verify the integer portion of the engine hours is correct as ordered. Release the switch and verify that the decimal portion of the engine hours is correct.
- 17 Tap the left button and note that the left magneto signal loss indicator begins flashing. This indication shows that the left internal tachometer has been masked from the display. Press the button again to stop the flashing.
- 18 Tap the right button and note that the right magneto signal loss indicator begins flashing. This indication shows that the right internal tachometer has been masked from the display. Press the button again to stop the flashing.
- 19 Tap the center button to dim the indicators, tap it again to restore to full intensity.
- 20 Prepare the aircraft for a safe engine start. Start the engine. The P-100 will show RPM within 2 seconds of engine starting. This startup period is used to train the tachometer. The display should faithfully follow the engine speed. Because cold engines, and engines operating out of their power bands will operate roughly, the tachometer can show sizable engine RPM variation.
- 21 At a suitable run-up area, perform a magneto drop check per your aircraft's flight manual. Remember to maintain the ignition switch at each position for a minimum of ten seconds, and always return to the "Both" position between grounding each agneto, ie. Move the switch as follows: BOTH-LEFT-BOTH-RIGHT-BOTH. As each magneto is grounded, not the LCD will show the change in engine RPM. This display lasts for 15 seconds, and then actual RPM is presented on the LCD.
- 22 Return the engine idle. Press the "Trap" button and hold it. Observe the maximum engine RPM achieved during the run-up operation.
- 23 Press and hold the "Clear" button. The LCD will show zero.
- 24 Press the "Trap" button and hold it again. Observe the maximum engine RPM achieved since the "Clear" button was pressed.
- 25 If possible, during engine operation compare the P-1000 RPM readings to your mechanical tachometer to verify that the P-1000 is operating properly.
- 26 Return the aircraft to the work area, and shut off.
- 27 Remove the mechanical tachometer and store.
- 28 Remove the tachometer drive cable and housing.
- 29 Patch the firewall hole using proper and approved materials and procedures.
- 30 Install the dust cap over the engine's tachometer drive attachment. Insure that the cap is rightly installed and won't shake loose. Use safety wire to secure cap in place. Periodically check the cap for proper fit, tightness, and oil leakage during its installation life.
- 31 Safety wire the cable to the tachometer. Two separate loops of stainless steel wire can be looped through each side of the connector and through corresponding drilled fillister head screw on the P-1000.
- 32 Install the P-100 in the instrument panel.

- 33 Secure all wires.
- 34 Make proper log book entries, including any deviations or corrections in engine/airframe time indicated on the tachometer.
- 35 Note any deviations in tachometer or circuit breaker location from those positions recommended in the drawing accompanying any STC'd P-1000.

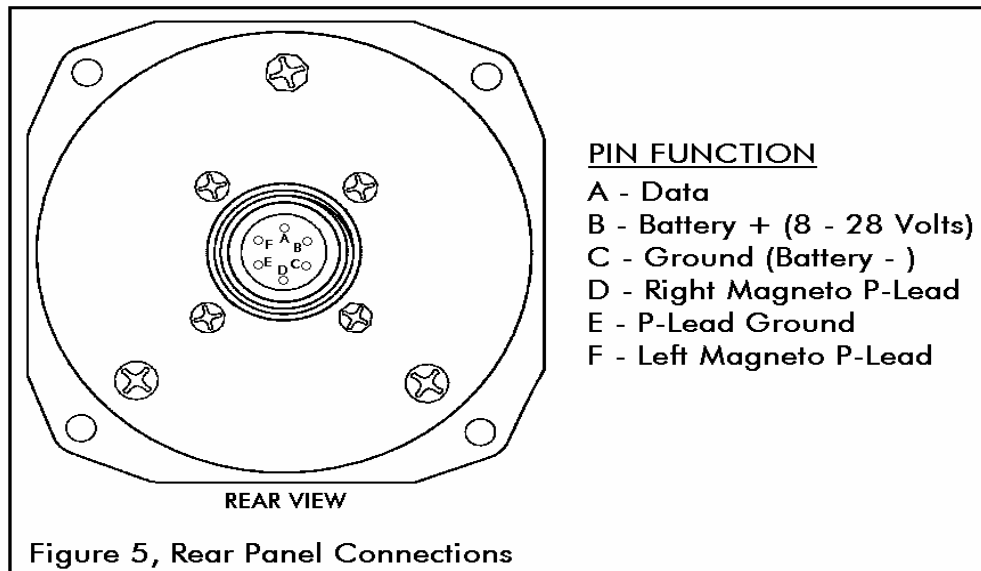

CONNECTIONS

A standard MS style connector is supplied on the rear of the P-1000 tachometer with six connections, as illustrated in Figure 5.

Using the pre-wired cable provided, black wire labeled "Ground" is connected to a suitable electrical ground of the aircraft's instrument power buss. The white, un-shielded, wire labeled "Battery+" is connected to supplied circuit breaker, connected to the positive voltage connection of the main power buss. Position the circuit breaker as indicated in any included installation drawings.

The "Right Magneto P-Lead" and "Left Magneto P-Lead" wires are connected to the right and left magneto P-leads at the

ignition switch (see Figure 6). **Do not connect any part of the P-1000 to a spark plug wire or any part of the high voltage secondary ignition circuit as serious damage may result to the P-1000 and to the pilot. Do not cut into any existing shielded P-Lead wire.**

Connection of the P-1000 P-Lead wires to the P-Leads at the ignition switch will provide for the best possible detection of hot-magneto/shorted-magneto conditions due to failing P-Lead wires or malfunctioning ignition switches.

The P-Lead wires supplied with the P-1000 are shielded, and the shields are terminated at the P-1000. Normal installation would not require that the other end of the shields be grounded, preventing the possibility of ground-loops from interfering with magneto/tachometer operation. Excessive noise problems may require alternation in the wiring/grounding techniques. The ends of the P-Lead wires are factory stripped clean of the shields, and protected from accidental contact with heat-shrinkable tubing, for ease of installation.

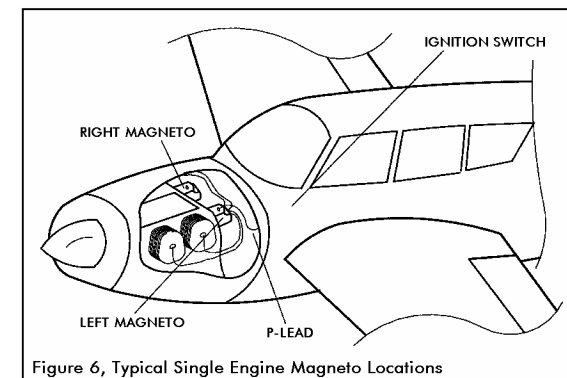

Caution should be taken when handling the connections to the magnetos. Magnetos can generate several hundred volts on their P-Leads that can provide sever shock hazard to the installer.

P-Leads wires should not be bundled with sensitive radio/communication/navigation instrument wires. Magnetic and electrical fields may exist around these P-Lead wires that can induce errors and noise into sensitive systems. Preferable routing is along grounded panel and frame members. Maintain at least 1 ½ inches of clearance between P-Leads and other sensitive circuits.

Keep in mind the following additional guidelines:

- Wires and cables shall be positioned or protected to avoid contact with rough or irregular surfaces and sharp edges.
- Wire dress or cabling of wires shall not result in improper electrical operation or interference with any mechanical operation that will lead to subsequent damage of the wire or cable.
- Cabling or wiring harnesses shall be anchored to avoid damage to conductors or adjacent parts.
- There will be no evidence of burns, abrading, or pinch marks in the insulation that could cause short circuits or leakage. Contact Horizon Instruments, Inc. for replacement of any suspect cable product.
- The clearance between wires or cables and heat generating parts, such as tubes, power resistors, heating and air-conditioning, shall be such as to avoid deterioration of the wires or cables from the heat dissipated by these parts under the specified service conditions of the equipment.
- Shielding on wires and cables shall be secured in a manner that will prevent it from contacting or shorting exposed current carrying parts.

REMOVAL OF MECHANICAL TACHOMETER

The existing mechanical tachometer must be removed and the P-1000 installed in the location indicated in the attached drawings. The tachometer drive cable should also be removed and the engine drive attachment be capped with the cap supplied in your hardware kit. The cap will keep dust out of the oil seals and prevent premature seal failure. The fire-wall must be soundly and properly patched with approved materials and techniques.

INSTRUMENT MOUNTING

As shown in Figure 7, the P-1000 should be positions to allow for optimum view of the LCD display. The pilot's line of sight to the P-1000 should be within the indicated angles. Viewing from greater angles will result in decreased readability of the display in low-light conditions.

Although special High-Intensity LED indicators are provided to overcome the possible "washout" conditions when exposed to direct sunlight, the P-1000 should be positioned on the instrument panel to avoid direct exposure to sunlight, especially during early morning and late afternoon when the sun is low on the horizon and light is most likely to shine directly on the instrument panels.

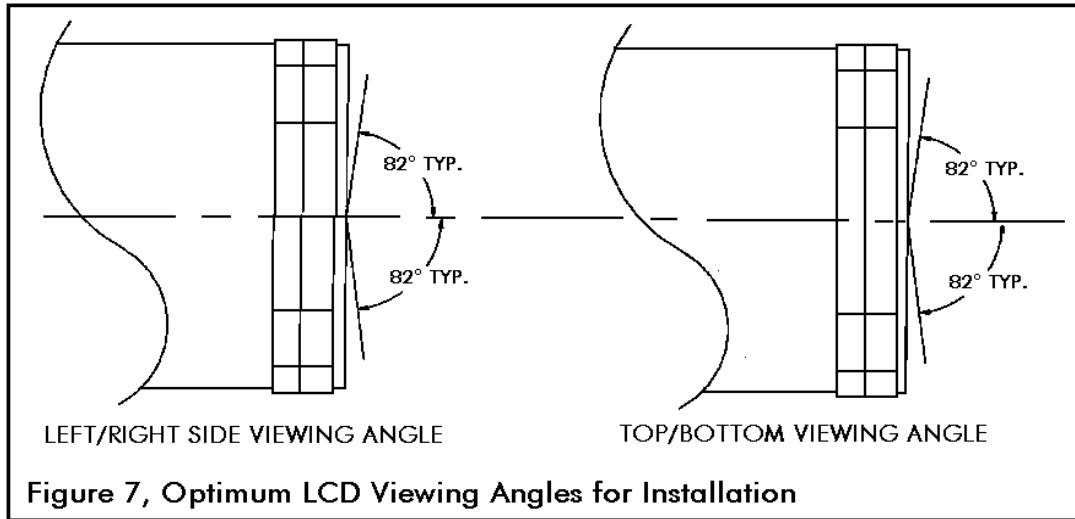

See the attached drawing package for tachometer placement requirements and wiring information pertinent to your application or STC.

A hardware packet has been supplied containing the necessary installation hardware, including: lock washers, screws and optional speed nuts, for normal panel installation.

Make all electrical connections prior to installing the tachometer into the panel. For additional security, the MS style connector should be safety-wired to the P-1000 case via the Drilled-Fillister head type screws provided.

CIRCUIT BREAKER

A circuit breaker has been supplied with your tachometer. For most STC installations, this breaker should closely match the original factory OEM circuit breaker. Whenever possible, install the breaker in the recommended position indicated on any attached drawings. If this location is occupied, select the closest location available. One terminal of the circuit breaker should be connected to the primary power buss (not the avionics buss), and the other terminal will have the white battery wire from the P-1000 attached to it.

The cable supplied has not yet had its power wires terminated. Two ring-tongue terminals are supplied for this purpose. When the circuit breaker and tachometer are located on the panel, the length of these two wires may be determined, and they can be cut to proper length prior to installation of the ring tongue terminals. Remember to include additional length for service loops (12 inches) and strain relief.

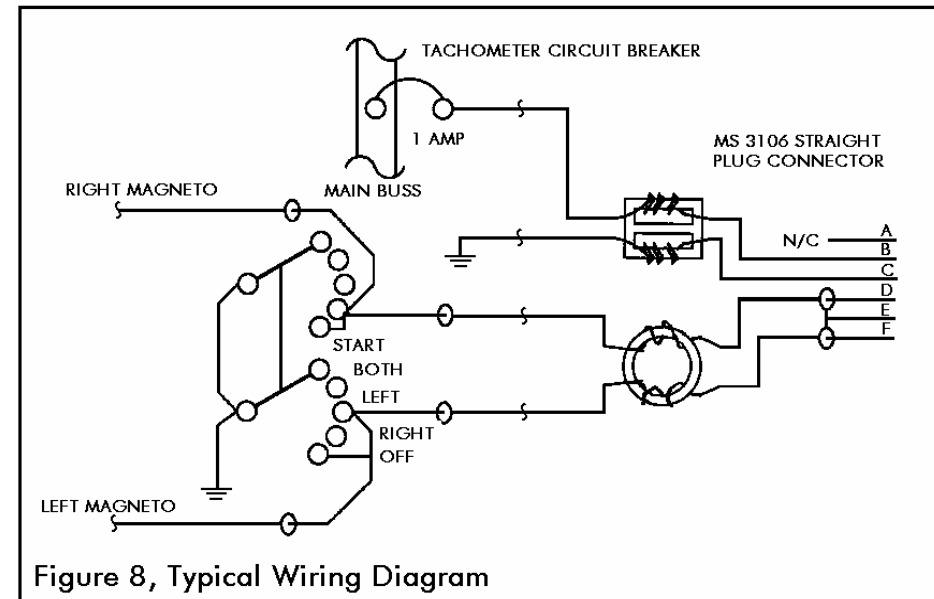

MAINTENANCE

The only maintenance required by the P-1000 is the possible replacement of the internal electroluminescent lamp, and an occasional cleaning.

Lamp replacement must be done by the manufacturer or a designated repair facility. Life expectancy of the lamp is greater than 10,000 hours.

The P-1000 should be kept clean of dirt, oil, and grease, by using a mild soap and water mixture with a soft non-abrasive cloth to maintain its appearance. Do not use harsh soaps or cleaning solvents as they can damage the case and its appearance. The P-1000 is not a sealed instrument; however the internal electronics have a protective coating. Avoid using excessive amount of spray cleaner or liquids that will penetrate into the interior of the tachometer.

TROUBLE-SHOOTING

The following is a brief chart of some of the different ways the P-1000 will behave under certain circumstances. It is assumed that the P-1000 is properly installed.

BEHAVIOR:

RPM drop during pre-flight magneto test is excessive.

P-1000 continuously indicated excessive RPM difference for right and left magnetos (Greater than allowed for this aircraft).

P-1000 continuously displays "Mag-Drop" indication with unstable displayed information.

Erratic or non-stable RPM readings on the P-1000.

RPM becomes unstable at higher engine speeds.

No engine RPM reduction when magneto is grounded by ignition switch.

P-1000 indicated no RPM. Engine runs and ignition switch is not shorting magneto.

RPM becomes unstable or inaccurate as engine warms up.

Red or Yellow Status LEDs flicker.

Yellow Status LED is on without either RED LED.

PROBABLE CAUSE:

Failing ignition system. Probable weak magneto or high-voltage components (ignition wires, plugs, etc.).

This is a common indication of degradation of one of the two ignition systems. The ignition system with the lesser RPM may be mis-firing.

P-1000 has an intermittent connection to a magneto (missing signals at P-1000).

Low magneto power output, bad connection, or bad magneto points.

Suspect point floating or possible ignition coil failure.

Possible hot magneto condition, P-Lead signal is not grounded. Possible open P-Lead wire or non-functional ignition switch.

P-Lead wires may be "open" or broken. Magneto signal is not arriving at switch connection. Power buss ground is floated from magneto, or P-100 has no connection to magneto ground.

Probable bad magneto points, bad bearing.

Intermittent connection in P-Lead or possible grounding of P-Lead. Check for loose connection at magneto, bad ignition switch, and breached insulation on P-Lead wire. Possible bad magneto.

Indicates that the magnetos are not supplying the same number of pulses (i.e. One for each cylinder). This generally indicates bad points or an intermittent connection.

BEHAVIOR:

Red status LED flashed regularly.

PROBABLE CAUSE:

Check to see that the tachometer has not been accidentally shut down. Quickly press and release the corresponding right or left tachometer control buttons to see if the condition clears.

COMMON FAILURES OF IGNITION SYSTEM

Loose connection at magneto.	Vibration of the engine can loosen the nuts/fittings where the P-lead terminates at the magneto.
Breached/Broken Insulation	Heating/Cooling can deteriorate insulation on old wire, vibration can cause object to wear through the insulation (the firewall is a likely location).
Broken Ignition Switch	Wafers/wipers inside the switch become loose or worn, debris (dust and dirt also) causes accidental shorts.

WARRANTY

Horizon Instruments warrants this product to be free from defects in material or workmanship under normal use and service. Horizon Instruments' obligation is limited to the repair or replacement of the defective product, which shall, within two years after shipment to the original purchaser, be returned to Horizon Instruments, with transportation charges pre-repaired, and which upon examination shall disclose to Horizon Instruments' satisfaction to have been thus defective and not subject to issue, improper installation, abuse or accident. This warranty is in lieu of all other warranties, expressed or implied, and all other obligations or liabilities on Horizon Instruments' part, and horizon Instruments neither assumes or authorized on any other person to assume any other liability in connection with the sale of Horizon Instruments' products.

In no event will Horizon Instruments be responsible for consequential damages resulting from the use of this product.

The following page contains a form you can use to register change of address, change of ownership, or to register a comment. It is included for your convenience and will help Horizon Instruments, Inc. better serve your needs in the future. Please photocopy the form from this manual, fill it out, and mail to the indicated address. Do not tear out the original, save it for the future use/owner.

The warranty is automatically registered to the original purchaser of the P-1000. If you change of ownership of the aircraft occurs, the following form can be used to notify Horizon Instruments, Inc. of the change and keep the warranty in force.

Mail to: **HORIZON INSTRUMENTS, INC.**
600 S. Jefferson St., Unit C.
Placentia, CA 92870

THIS FORM IS BEING USED TO:

- Change Address of Owner
- Change of Aircraft Owner
- Make a Comment
- Removal/Destruction/Discontinued Use of P-1000

P-1000 Part Number & Serial Number:

CURRENT INFORMATION:

Owner Name:

Address:

City:

State:

Zip/Routing Code:

Phone Number:

AIRCRAFT INFORMATION:

Make:

Model:

Serial No.:

Registration No.:

NEW INFORMATION:

Owner Name:

Address:

City:

State:

Zip/Routing Code:

Phone Number:

COMMENTS:

(Please make a copy of this original page, fill out the copy and mail or fax it to Horizon Instruments, Inc. Make another copy of the completed form for your records.)